



# User's Guide

# D0106LT-33-0604N

# VFD- **RoHS Compliant**

(Vacuum Fluorescent Display Module)

---

For product support, contact

**Newhaven Display International, LLC**  
**2511 Technology Drive, #101**  
**Elgin, IL 60124**  
Tel: (847) 844-8795 Fax: (847) 844-8796

*February 20, 2008*

# Vacuum Fluorescent Display Specification

**PART NUMBER:** **D0106LT-33-0604N**

**FEATURES:** 6 Digits, 7-Segmented, Instrumentation

**APPLICATION:** Character Display (*7-Segmented*)

**RATINGS:** Below

<b>Outer Dimensions</b>	Panel Length	P.L.	98.0	mm	
	Panel Height	P.H.	33.0	mm	
	Panel Thickness	P.T.	8.0	mm	
<b>Leads</b>	Lead Pitch	L.P.	2.54	mm	
	Lead Out	-	SIL		
<b>Character Size</b>	Character Height	C.H.	12.4	mm	
	Character Width	C.W.	6.8	mm	
<b>Item</b>	<b>Symbol</b>	<b>Min.</b>	<b>Recommended</b>	<b>Max.</b>	<b>Unit</b>
<b>Filament Voltage</b>	Ef	3.42	3.8	4.12	Vac
<b>Peak Grid Voltage</b>	ec	-	26.0	33.0	Vp-p
<b>Peak Anode Voltage</b>	eb	-	26.0	33.0	Vp-p
-	-	-	-	-	-
<b>Duty Cycle</b>	Du	-	1/7	-	-
<b>Pulse Width</b>	tp	-	200	-	uS
<b>Operating Temperature</b>	Topr	-20	-	+ 70	C
<b>Storage Temperature</b>	Tstg	-55	-	+ 80	C
<b>Color of Illumination</b>	Green				

**D0106LT-33-0604N**

**Electrical  
Characteristics**

Item	Symbol	Test Condition	Min.	Typical	Max.	Unit
<b>Filament Current</b>	if	Ef = 3.8 Vac	97.0	108.0	119.0	mAac
	-	eb = ec = 0	-	-	-	-
<b>Anode Current</b>	ib/1G~6G	Ef = 3.8 Vac eb = 26.0 Vp-p ec = 26.0 Vp-p Du = 1/7 Tp = 200 uS	-	5.0	10.0	mAp-p
	-		-	-	-	mAp-p
	-		-	-	-	mAp-p
	-		-	-	-	mAp-p
	-		-	-	-	mAp-p
<b>Grid Current</b>	ic / 1G~6G		-	7.0	14.0	MAp-p
	-		-	-	-	MAp-p
	-		-	-	-	MAp-p
	-		-	-	-	MAp-p
	-		-	-	-	MAp-p
<b>Luminance</b>	L(G)		350	700	-	cd/m <sup>2</sup>
	-		(102)	(204)	-	fL
<b>Luminance Ratio</b>	Lmin/Lmax		50	-	-	%
<b>Grid Cut-off Voltage</b>	Ecco	Ef = 3.8 Vac eb = 26.0 Vdc	-4.0	-	-	Vdc
<b>Anode Cut-off Voltage</b>	Ebco	Ef = 3.8 Vac ec = 26.0 Vp-p Du = 1/7 Tp = 200uS	-2.0	-	-	Vdc

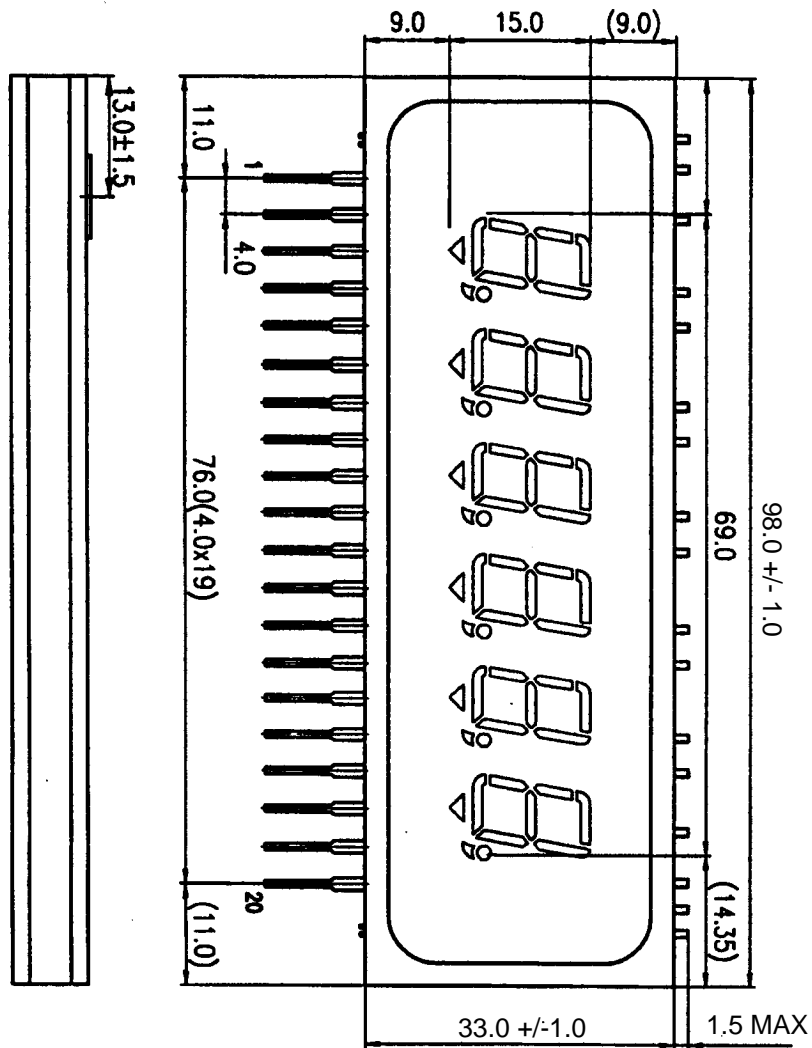

Notes: F: Filament G: Grid NC: No Connect P: Anode

Pin No.	1	2	3	4	5	6	7	8	9	10	11	12	13	14	15	16	17	18	19	20
Connect	F	NC	6G	P(φ)	P(φ)	5G	P(φ)	P(φ)	4G	P(φ)	NC	3G	P(φ)	P(φ)	2G	P(φ)	P(φ)	1G	P(φ)	F

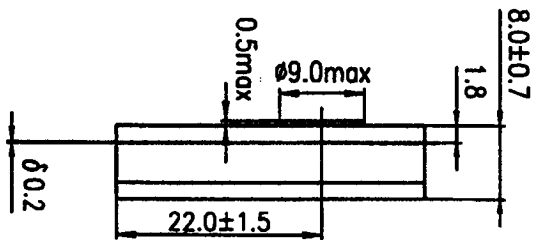
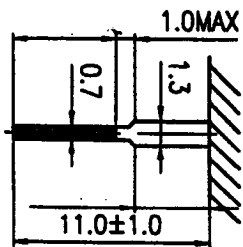

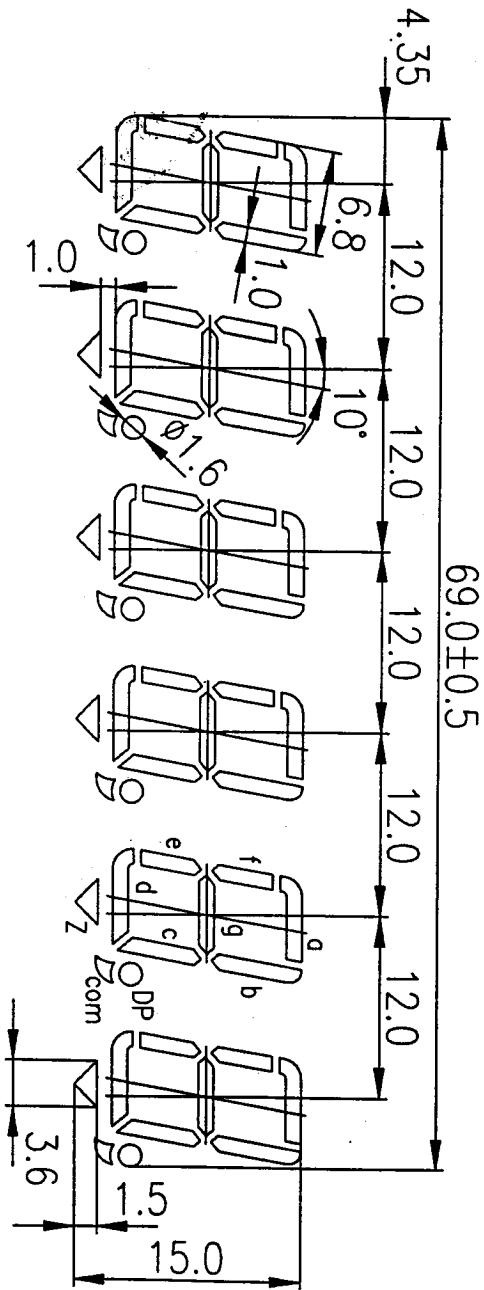
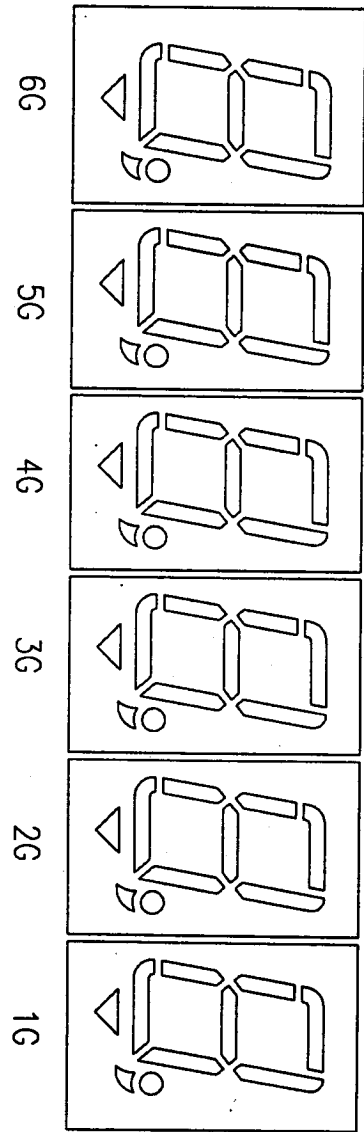

	1G	2G	3G	4G	5G	6G
P1	a	a	a	a	a	a
P2	b	b	b	b	b	b
P3	c	c	c	c	c	c
P4	dp	dp	dp	dp	dp	dp
P5	COM	COM	COM	COM	COM	COM
P6	▽	▽	▽	▽	▽	▽
P7	d	d	d	d	d	d
P8	e	e	e	e	e	e
P9	f	f	f	f	f	f
P10	g	g	g	g	g	g